



Soliur-XS7-Pro

Outdoor Solar Wireless Camera

USER MANUAL

PACKING LIST

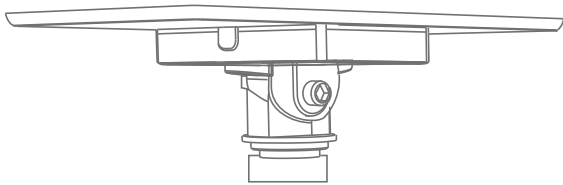

1 Solar panel

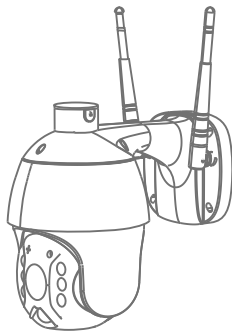

1 PTZ Camera

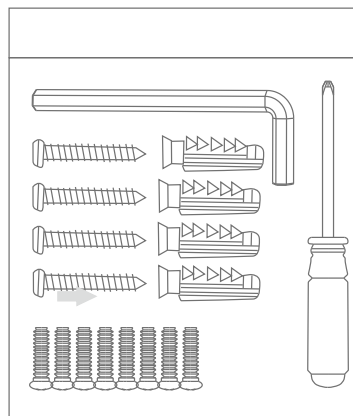

1 Screw kit

- 1 Hexagon spanner
- 1 Screw driver
- 8 Screws
- 4 Tapping screw
- 1 USB charging cable

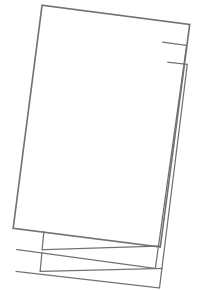

1 User manual

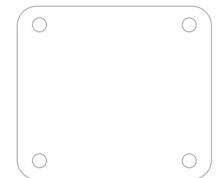

1 Position paper

Product Diagram

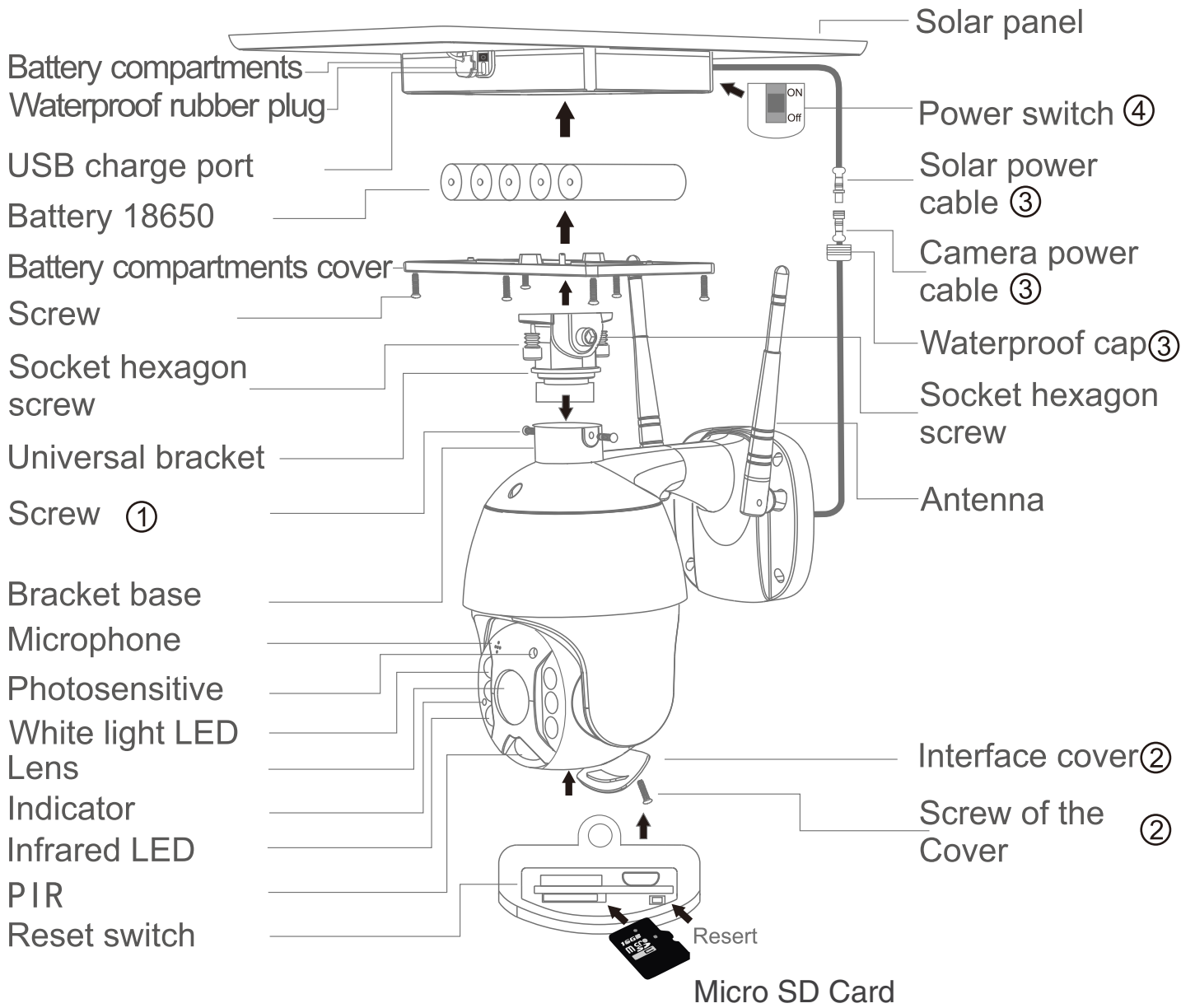

1.SETUP

Connect the cable from the solar panel to the cable coming out of the camera ③ and screw on the waterproof cap.

Power up:

Remove the **rubber plug** from the solar panel to find the power switch ④. When you move the switch to the ON position the camera should power up right away, if not, the battery in the solar panel module needs to be charged.

Charging:

To charge you can simply leave the panel exposed to sunlight for the day. A full charge will require that the panel is exposed to sunlight for about 12 hours. For a faster charge connect the included USB cable to the **USB charge port** and a USB wall adapter.

2 .INSTALLATION

2.1 Intergrated installation

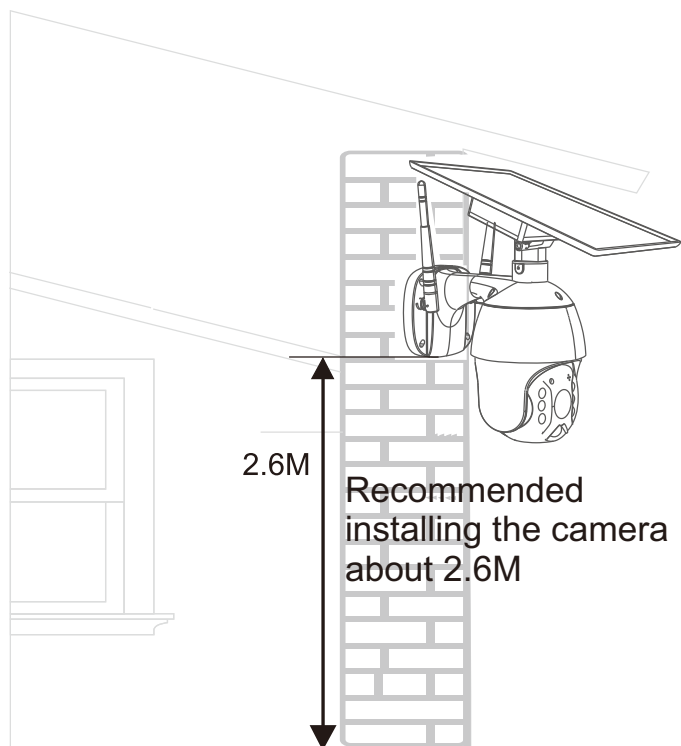

2.2 Separated installation

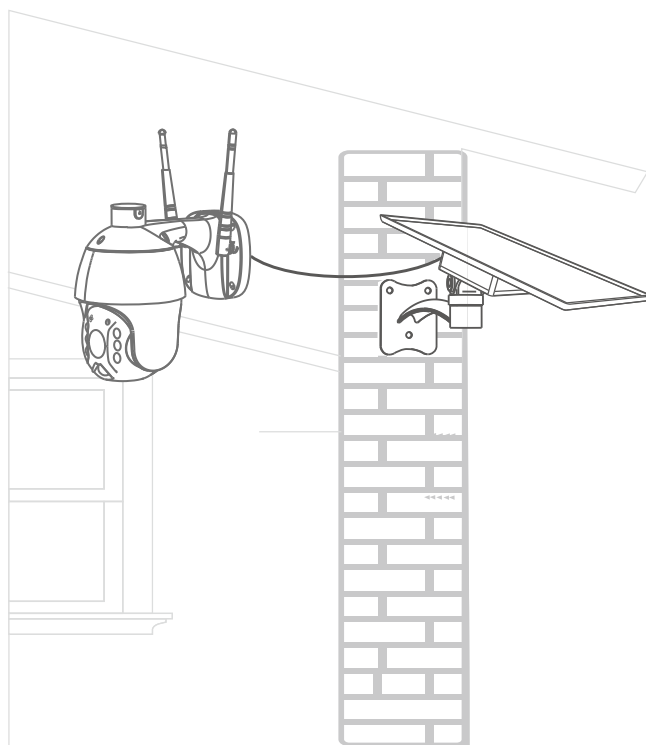

Accessories needed
(not standard configuration)

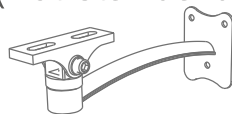

1*Bracket



1*Extra power cable 2M

3. APP INSTALLATION

3.1. Scan the following QR codes or search for “UBox” from the App Store(for iOS devices) or Google Play Store (for Android smartphones) to download and install the app.



IOS



Android

3.2. APP REGISTRATION

3. 2. 1.Open the app then input your E-mail address then press 'Register'. Check and select to agree the agreement then your E-mail box will get an verification code.(For better user's experience, please allow to open all permissions to avoid missing any notifications from the app.)

3. 2. 2. Input the “Verification code” and press 'Next'. (if you not found the mail you might find the code in your email spam box.)

3.2.3. Set the login password and confirm the login password. Then press 'Register' to next step. (For your password safety, the password requires more than 8 characters plus a combination of letters)

3.2.4. Enter your E-mail address, and input your login password. Then press 'Login'.

Please enter your email

Register

Registered account means you agree to UBIA User Agreement



We have sent a verification code to
18818587***
Verification code

Verification code [Resend\(58\)](#)

Next

Please set the login password

Please confirm the login password

The password is a combination of 8-32 English letters and numbers

Register



Please enter your email

Please enter your login password

Remember [Forgot](#)

Login

4. WI-FI CONNECTION

4.1. Press 'Add Family' then set the room or position as per reminders.

4.2. Enter your family name and then press 'Next'.

4.3. Input the necessary information just like Country, Province, then press 'Done'.

4.4. Press 'Add a device' to add a smart device

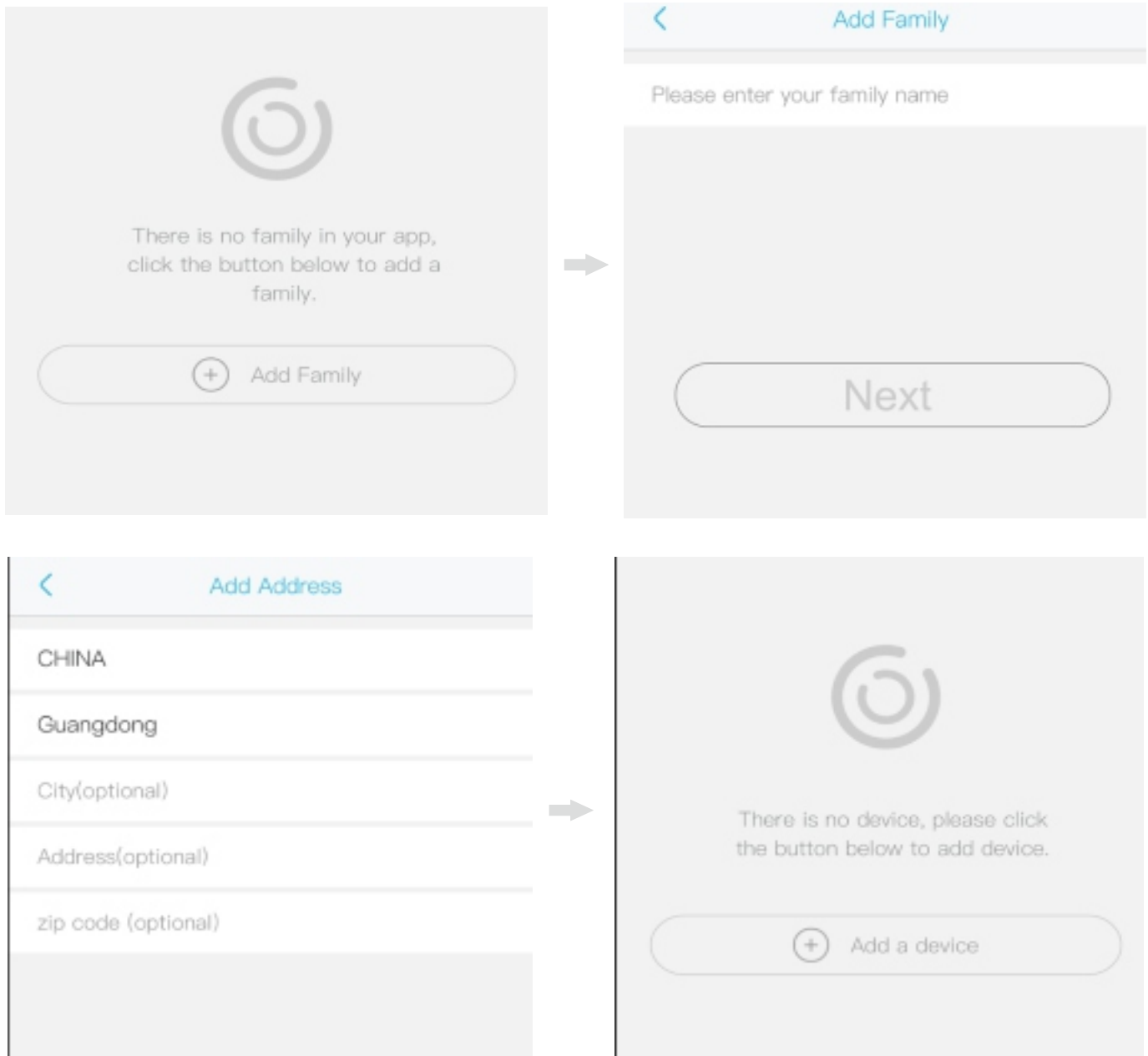

- 4.5. Connect the device with power supply, and make sure your mobile phone is connected to an available Wi-Fi. Then press 'Setup device'
- 4.6 After the power on the device, wait for the blue LED and voice prompt. The device is waiting for pairing, which means your device is in pairing mode.
- 4.7. If you did not hear the voice prompt, please press the RESET button until the blue indicator lights up and then release. The device will reboot and enter the pairing state.
- 4.8. The app will input the Wi-Fi name automatically, please input the correct Wi-Fi Password. Then you can choose the 'QR code configuration' or 'Sound wave configuration'.
- 4.9. Sound wave configuration: Make sure camera and mobile phone within 1M distance, you will hear the wave sound DI DI, follow the tips showed in the mobile to finish configuration.

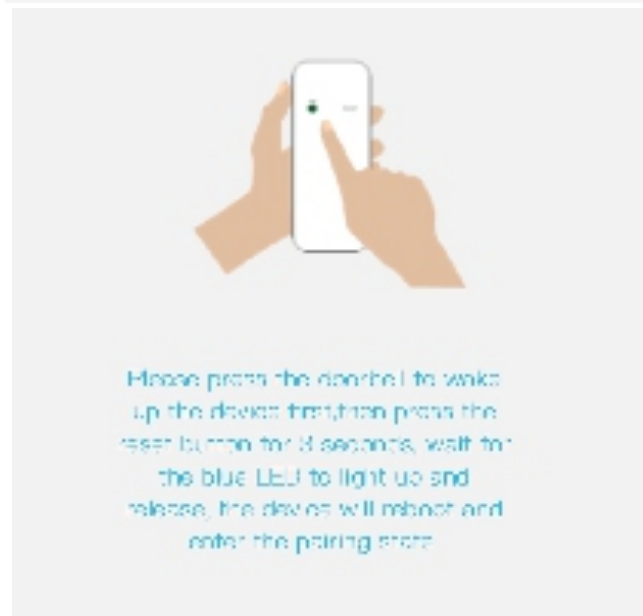

- 4.10. QR code configuration: Select the QR code configuration then the mobile phone display a QR code. Use the device to scan to the QR code 10cm away from the mobile phone.
- 4.11. Select the family name or device location then press 'Done.'
- 4.11. The device will enter to the device list automatically. Setup success! The device is ready to use.

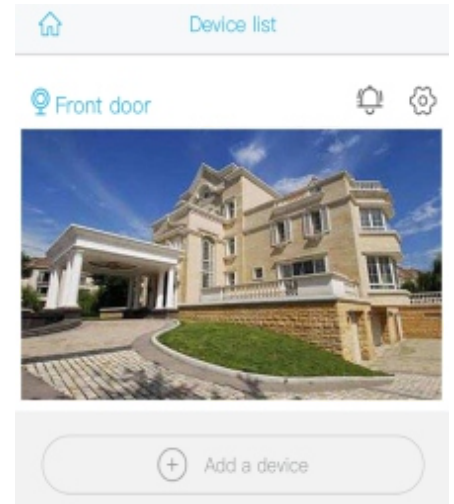
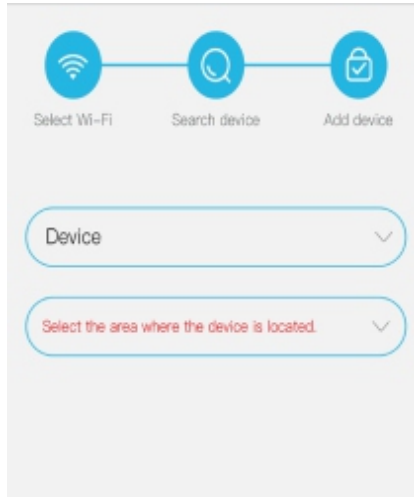

5. DEVICE SETTING

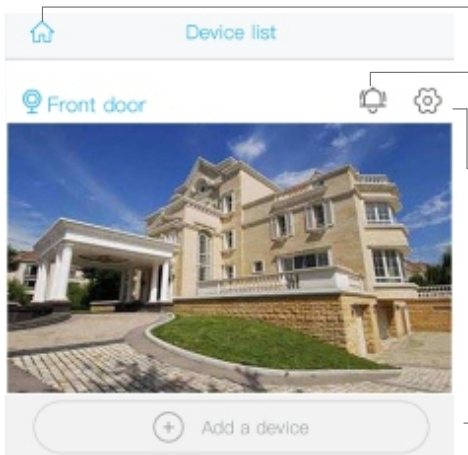

- Enter to select your family or smart device location
- Turn on/off the push notification.
- Settings: Sharing, Cloud storage, Delete the device..
- Press to enter the preview section.
- Press to add a smart device

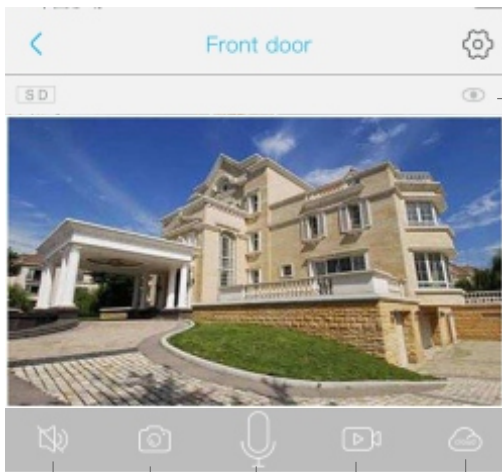

Smart device basic settings
 Could set "Storage management, Flip screen, Environmental model, PIR detection, Sleep time, Power frequency, LED indicator, Device name"
 Could check the information of "Device name, Device ID, Model, FW version, Manufacturer, Check for the FW updates.."

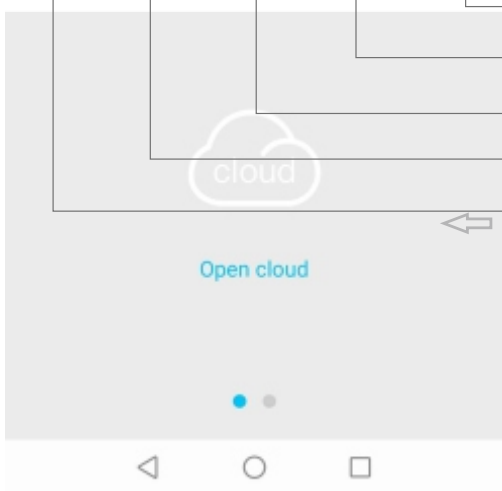

Start Cloud service

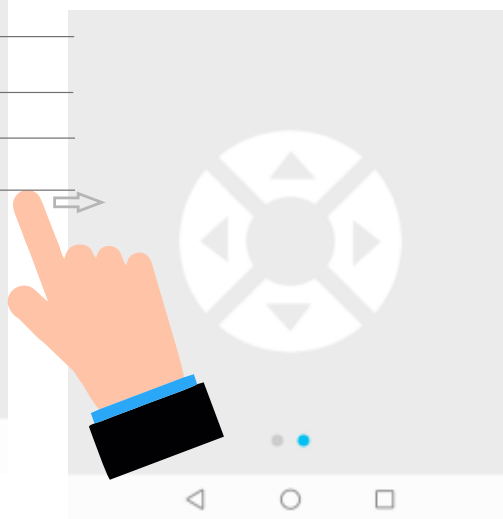

Pan tilt control



Check "my account" name and change password;

1282947798@qq.com
18818587****

- Cloud Service > Check and purchase the Cloud storage;
- Face recognition > Check and purchase the AI Cloud Facial Recognition;
- My Friends > Check and add my friends list and permission;
- Common Settings > Set the default voice and resolution for the devices;
- About >

Logout

- Device
- Cloud video
- Album
- Me

"My account" menu

6. CLOUD SERVICE

You have the option to record media on the cloud service where it can be accessed any time remotely. 30 day to 1 year service is available and your can purchase it via credit or Paypal. Paypal is recomendaded.

Cloud Service Purchase

Device
Please select the service you want to open or renew:

- Cloud Storage
Upload video cloud storage
- 30day \$1.99
- 180day \$8.99
- 360day \$16.99

Device

2020-09-18 17:24:59

2020-09-18

- PM 05:24 Device Activity detected length:10s
- PM 05:13 Device Activity detected length:10s

Tap the cloud icon to access recordings or you can also access it via the calendar to filter videos by date.

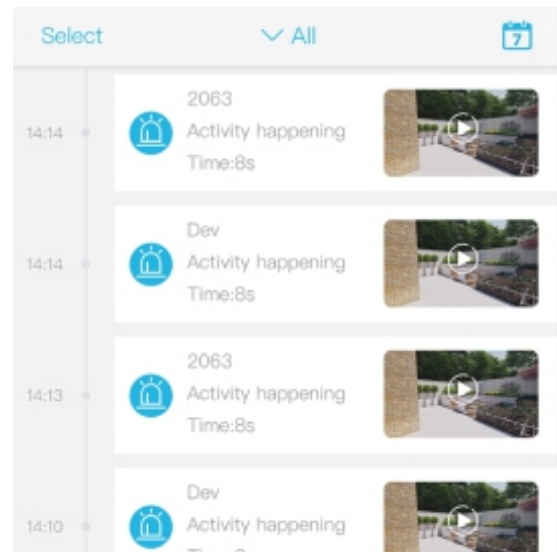
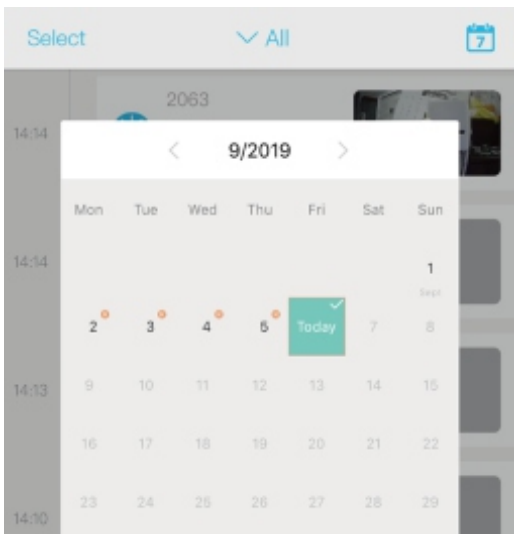

7. MY FRIENDS AND SHARING

To share media you must first add another user from the network. On the other user's phone in "My account" screen tap the profile icon to access his or her's or account QR code, on your phone tap **My Friends, Add Friend** and **Scan QR to add**, and then scan the other user's QR code on screen to add.

Other user's phone

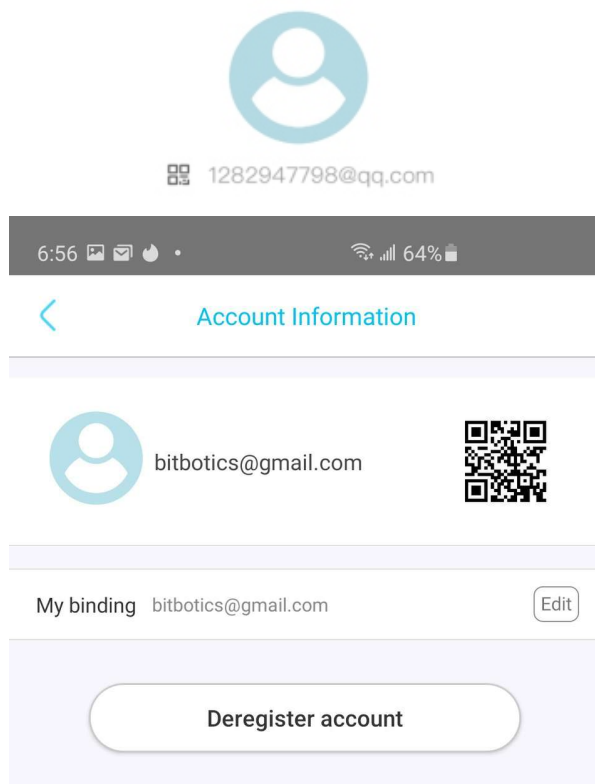

Your phone

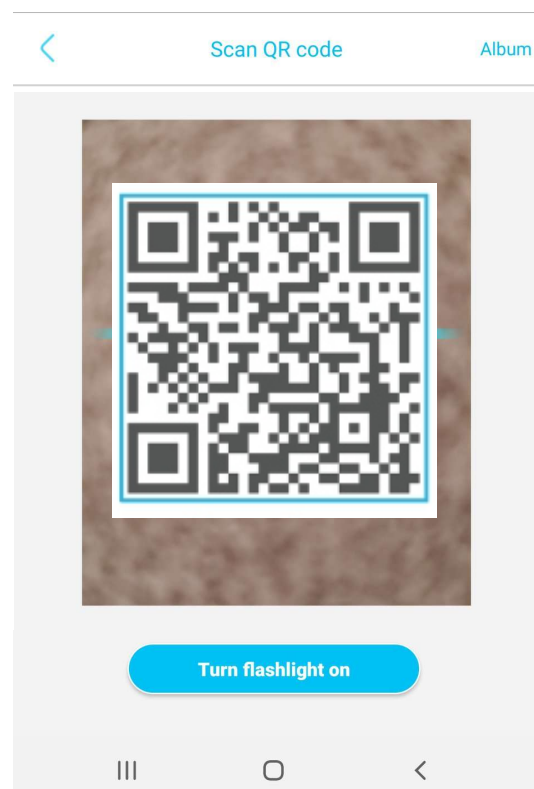

8. ADDITIONAL INFO

- ▶ .The device is equipped with a rechargeable lithium battery. The battery life will be affected by the device wake-up time and the number of wake-ups. Therefore, the PIR sensor alarm detection function is used in an environment with a lot of people. It is recommended to turn off or set the device to low sensitivity to reduce device wake-up and call times extend battery life. When the battery is low, please charge the battery immediately.
- ▶ Keep the device in range of your router. Make sure the device is placed close to the Wi-Fi router. If there has to be thick or insulated objects between the device and the Wi-Fi router, which may lead to weak Wi-Fi signal, please make sure the Wi-Fi signal is in good level before you start using the device.
- ▶ It is a delicatated device with low power consumption design. Everytime the device is awakened and will work for few seconds. After that, the device will enter standby mode to save power. You can set the work time in the app settings.
- ▶ Because the mainland China does not receive Google's system push messages, you need to open the app's self-starting function in your phone to receive push messages.
- ▶ This device provides one month of free cloud storage services. If you need to continue using value-added services after the trial period expires, you need to purchase them in the app.

9. SUPPORT AND WARRANTY

For technical support or warranty information please contact your place of purchase.



Scan the QR code to download an updated PDF version of this manual.